



140-180t/h 3 IN 1 MOBILE CRUSHING PLANT



AIMIX GROUP CO., LTD.

QUOTATION

CONTENTS

Company Introduction	1
Why Choose Us	2
Customer Requirements	3
Scheme 3D Display	4
Advantages of the Product	5
Scheme Drawings	6
Scheme Configuration	7
Main crusher List	10
Certificates	14
What services can Aimix offer?	15
File Support	16
Project Cases	17
What Our Partners Say	21
Aimix Global Market	22

COMPANY INTRODUCTION

AIMIX is a manufacturer with a mission of "To build a better world together". We specialize in the design, production, delivery, and operation of construction machinery.

AIMIX is a leading player in China's construction equipment industry and our products have been exported to over 100 countries and regions around the world, providing equipment and services to Fortune 500 companies such as Lafarge, Posco, Wilmar group, and more.

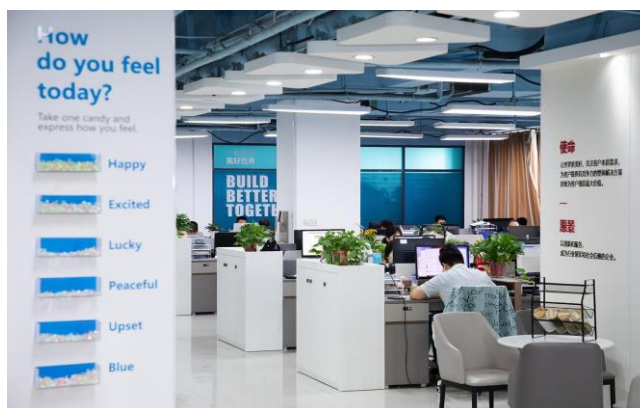
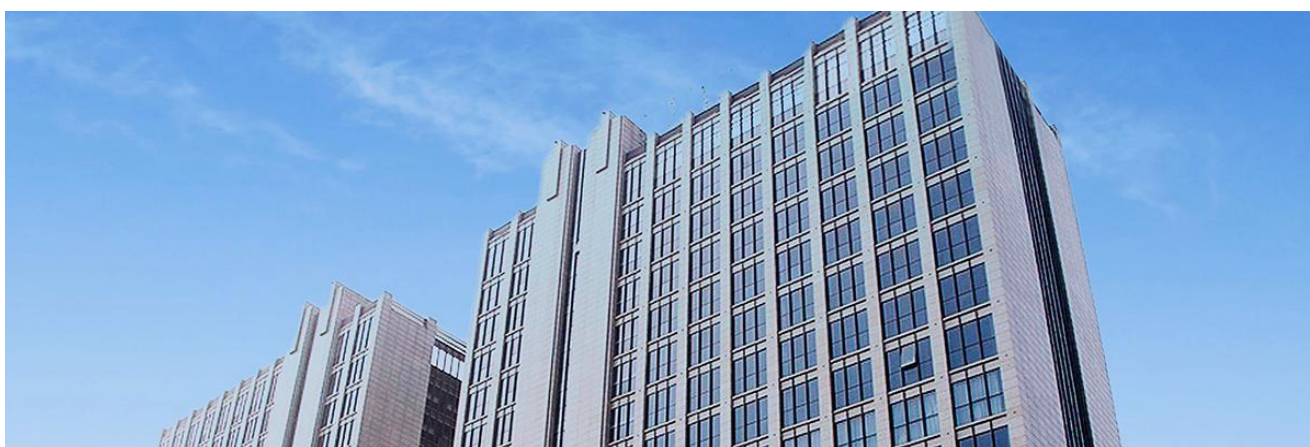

WHY CHOOSE US

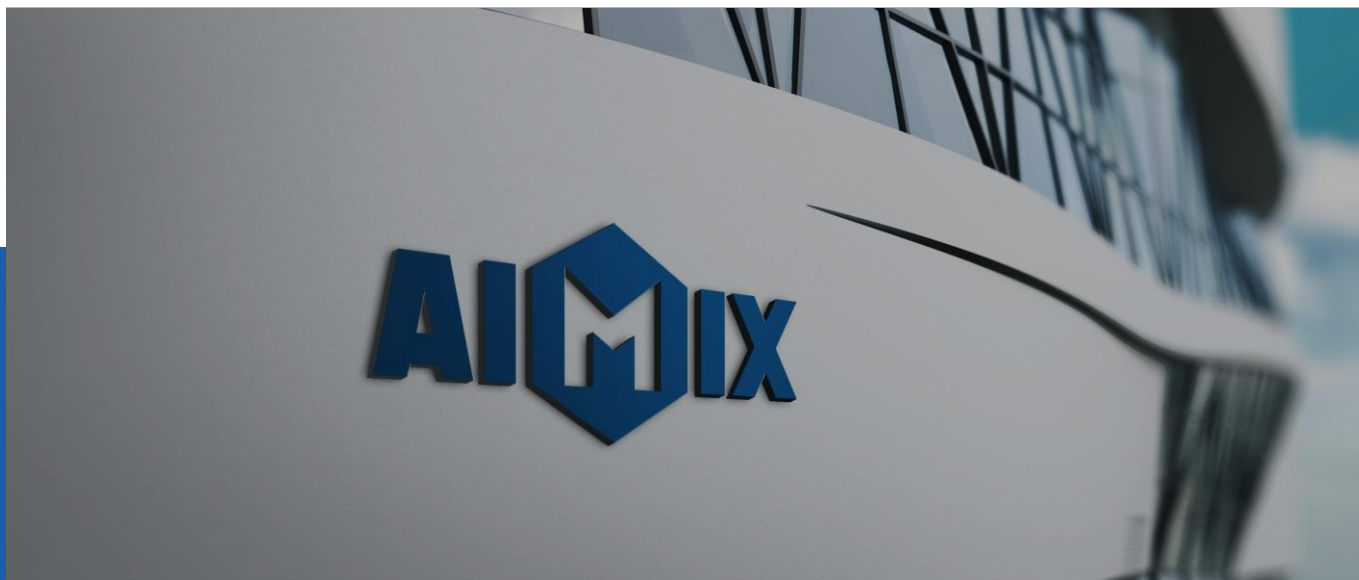

High-quality products

AIMIX's products are characterized by high quality, reliability, and cost-effectiveness, ensuring long-term value for customers.



Professional pre-sales consulting planning

AIMIX's sales team has rich industry experience and professional knowledge, and can provide comprehensive pre-sales consulting planning to ensure that customers choose the most suitable products.



24/7 after-sales service

AIMIX provides 24/7 after-sales service to ensure the stable operation of equipment and customer satisfaction, providing long-term support to customers.



Professional technical team support

AIMIX has a professional technical team and delivery team to support customized solution design and delivery, and can provide customers with timely and professional technical support and delivery services.



Fast supply of spare parts

AIMIX has a complete spare parts supply system, which can quickly provide customers with the required spare parts to ensure efficient equipment operation.

ADVANTAGES

CUSTOMER REQUIREMENTS



Raw
Material:
Concrete
Waste

Feeding
Size:
600mm

Outlet
size:
0 -45MM

Capacity:
140-180TPH

Electricity:
380V,
50HZ

SCHEME 3D DISPLAY



ADVANTAGES OF THE PRODUCT

The 3 in 1 mobile crushing plant is a mobile crushing equipment that integrates crushing, screening, conveying, crushing and screening, and has the following advantages:

- 01 Strong Mobility**
Easily moved between different construction sites, reducing the cost and time of equipment relocation, and is suitable for multi-point operations.
- 02 Comprehensive Functions**
Integrates crushing, screening, conveying, crushing and screening, and can complete multiple steps of processing work, thereby reducing the number of equipment and floor space.
- 03 Easy to operate**
Equipped with an advanced automatic control system, which is easy to operate and can realize remote monitoring and remote control, reducing the difficulty of manual operation and management.
- 04 Low Cost**
Integrates multiple functions, reduces equipment purchase and maintenance costs, and saves land and transportation costs, helping to reduce
- 05 Easy to install**
Overall frame, integrated transportation, easy to trans

ADVANTAGES

SCHEME DRAWINGS

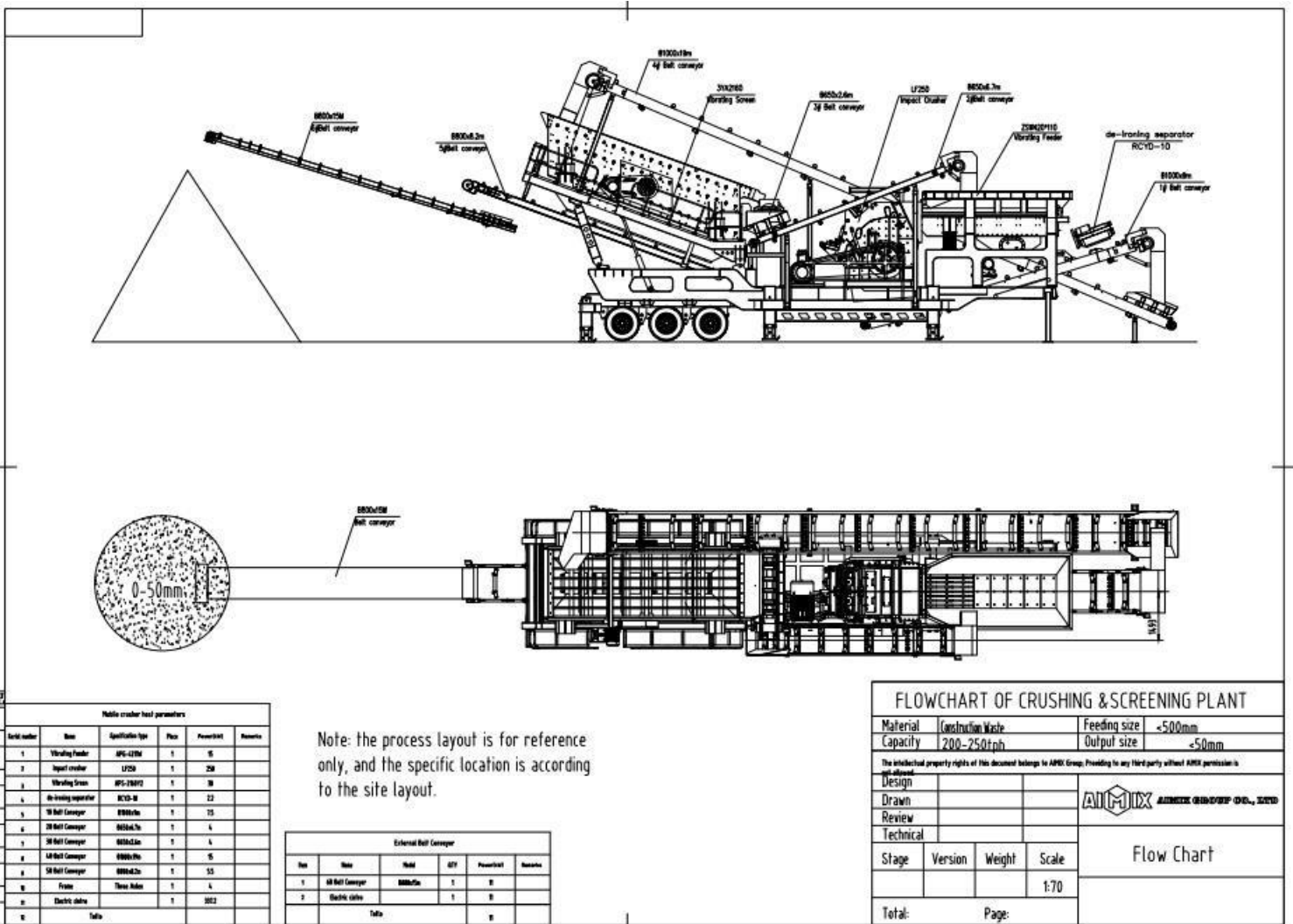

Mobile crusher host parameters					
Serial number	Item	Specification type	Price	Power/kW	Remarks
1	Vibrating Feeder	APC-L200	1	15	
2	Impact crusher	L750	1	250	
3	Vibrating Screen	APC-20012	1	30	
4	Air-ironing separator	RCYD-10	1	22	
5	1/2 Belt Conveyor	6000x2.6	1	75	
6	1/2 Belt Conveyor	6000x2.7	1	4	
7	1/2 Belt Conveyor	6000x2.6	1	4	
8	1/2 Belt Conveyor	6000x2.6	1	5	
9	1/2 Belt Conveyor	6000x2.6	1	55	
10	Frame	Three Axles	1	4	
11	Electric cables		1	1022	
12	Total				

Note: the process layout is for reference only, and the specific location is according to the site layout.

External Belt Conveyor					
Item	Item	Model	Qty	Power/kW	Remarks
1	1/2 Belt Conveyor	6000x2.6	1	0	
2	Electric cables		1	0	
	Total			0	

FLOWCHART OF CRUSHING & SCREENING PLANT			
Material	Construction Waste	Feeding size	<500mm
Capacity	200-250tph	Output size	<50mm
The intellectual property rights of this document belongs to AIMIX Group. Providing to any third party without AIMIX permission is not allowed.			
Design			
Drawn			
Review			
Technical			
Stage	Version	Weight	Scale
			1:70
Total:		Page:	





Flow Chart

SCHEME CONFIGURATION

ItemModel	Vibrating Feeder	Impact Crusher	Vibrating Screen	Alex	Transport size(mm)
APY-3-250	APG-4211W	APF-250	APS-2160Y2	3	18400X3300X4100



SCHEME CONFIGURATION

Photos	Specification	
	Model	APG-4211W
	Specification (mm)	1100X4200
	Max Feed Size (mm)	650
	Speed (rpm)	600-850
	Capacity(t/h)	180-400
	Power(KW)	15
Photos	Specification	
	Model	APF-250
	Feed Size (mm)	960X1360
	Product particle size(mm)	200-400
	Capacity(t/h)	200-400
	Power (KW)	250
Photos	Specification	
	Model	APS-2160Y2
	Screen Specification(mm)	2100x6000
	Screen mesh (mm)	300
	Max. Feed Size(mm)	300
	Capacity (m³/h)	81-720
	Double Amplitude (mm)	8
	Power (KW)	30

EQUIPMENT LIST

Photos	Internet of things																																								
	<table border="1" data-bbox="730 719 922 884"> <caption>время работы</caption> <tr><td>питатель</td><td>0</td><td>0</td><td>0</td></tr> <tr><td>оборочная машина</td><td>0</td><td>0</td><td>0</td></tr> <tr><td>транзитная перевозка</td><td>0</td><td>0</td><td>0</td></tr> <tr><td>конус 1</td><td>0</td><td>0</td><td>0</td></tr> <tr><td>конус 2</td><td>0</td><td>0</td><td>0</td></tr> <tr><td>машина сортировочной машины</td><td>0</td><td>0</td><td>0</td></tr> <tr><td>сортировочная машина 1</td><td>0</td><td>0</td><td>0</td></tr> <tr><td>сортировочная машина 2</td><td>0</td><td>0</td><td>0</td></tr> <tr><td>сортировочная машина 3</td><td>0</td><td>0</td><td>0</td></tr> <tr><td>сортировочная машина 4</td><td>0</td><td>0</td><td>0</td></tr> </table>	питатель	0	0	0	оборочная машина	0	0	0	транзитная перевозка	0	0	0	конус 1	0	0	0	конус 2	0	0	0	машина сортировочной машины	0	0	0	сортировочная машина 1	0	0	0	сортировочная машина 2	0	0	0	сортировочная машина 3	0	0	0	сортировочная машина 4	0	0	0
питатель	0	0	0																																						
оборочная машина	0	0	0																																						
транзитная перевозка	0	0	0																																						
конус 1	0	0	0																																						
конус 2	0	0	0																																						
машина сортировочной машины	0	0	0																																						
сортировочная машина 1	0	0	0																																						
сортировочная машина 2	0	0	0																																						
сортировочная машина 3	0	0	0																																						
сортировочная машина 4	0	0	0																																						

Belt conveyor

Width	Conveying length (m)/Power(Kw)			Speed (m/s)	Capacity (tph)
1000	10-15/11	15-23/15	23-32/22	1.3-2	288-696
800	10-15/7.5	15-20/11	20-30/15-18.5	1.3-1.6	184-445



QUATATION LIST

	Item	Model	Power(kW)	Quantity(set)
Mobile 3 in1 crusher plant	Vibrating Feeder	APG-4211W	7.5*2	1
	Impact crusher	APF-250	250	1
	Vibrating Screen	APS-2160Y2	30	1
	Vehicle Mounted Belt Conveyor	B1000X11M	11	1
	Vehicle Mounted Belt Conveyor	B800X21M	15	1
	Vehicle Mounted Belt Conveyor	B1000X8.5M	7.5	1
	Vehicle Mounted Belt Conveyor	B650X7M	5.5	1
	Permanent Magnetic Separator	RCYD-10	3	1
	three axle trailer (Material: Q345 manganese steel)	---	---	1
	Hydraulic lifting system	---	---	1
	Vehicle-mounted copper core cable, terminal box, shield, hopper and chutes	---	---	1
External belt conveyor (Including legs)	Belt Conveyor (OPTIONAL)	B650X12M	5.5	---
Control System	Electronic control system	Electric control cabinet	348	1
*Diesel generator set (OPTIONAL)	---	---	500KW	---
4 x 40HQ will be used for sea transportation. + 1. *If a generator is required, a 20ft container is included.				

WHAT SERVICES CAN AIMIX OFFER?

AIMIX provides a full-cycle A-to-Z service system, consisting of 4 phases and 14 modules.



A-To-Z service system

<p>Pre-sale consulting services</p>	<ol style="list-style-type: none"> 1. Providing demand docking services 2. Providing project planning services 3. Providing solution design services 	<ol style="list-style-type: none"> 4. Providing market information sharing services 5. Providing ROI analysis services
<p>In-sale service</p>	<ol style="list-style-type: none"> 1. Providing production information services: synchronizing production progress, sharing production photos and videos 2. Providing quality control services: testing and inspecting machines before shipment, support third party inspection 3. Providing transportation services: designing packaging, differentiating packaging, and strengthening protection, etc. 4. Provide customs clearance assistance services: regional customs clearance resource sharing, double clearance, door-to-door 	
<p>After-sale service</p>	<ol style="list-style-type: none"> 1. Providing after-sales training services: operational training, safety training, operational training, and maintenance training 2. Providing equipment installation services: online guidance, offline services, and on-site services 3. Providing trouble shooting services: responding within 24 hours, provide the solve solution ASAP 4. Providing regular follow-up services: regularly follow up on equipment operations and perform regular equipment maintenance. 	
<p>Valuation and rental/re-sale services</p>	<ol style="list-style-type: none"> 1. Providing valuation and sales services: after using the equipment, if the plan is to sell it, AIMIX provides valuation and rental/re-sale services. 	

FILE SUPPORT

There Are A Couple Of Technical Documents We Will Provide in Sequence:

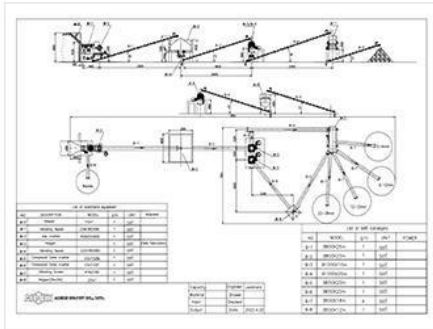

01/ Scheme Drawings



02/ 3D Diagram



03/ Mill Test Certificate



04/ Certificate

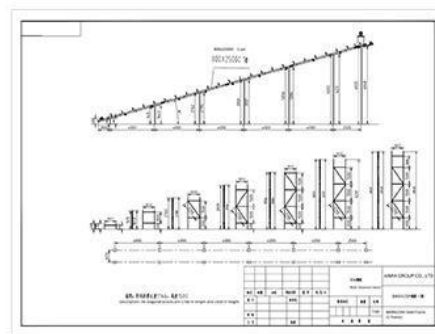

05/ Foundation Drawing

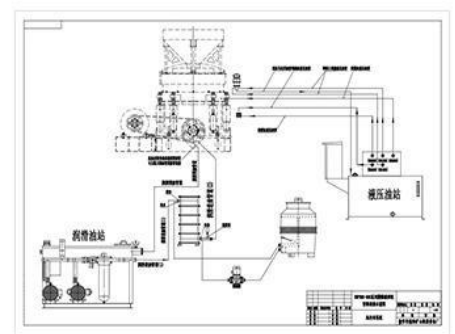

06/ Connection Drawing

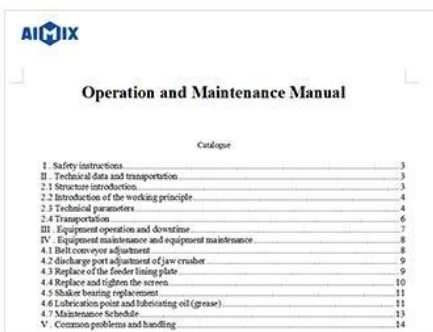

07/ Operation Manual



08/ Maintenance Manual

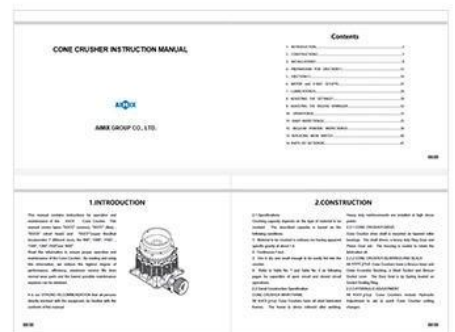

09/ Instruction Manual

PROJECT CASES

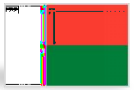

📍 Project place : Madagascar

📄 Project proposal: 4 in 1 mobile stone crusher

⚙️ Capacity : 30TPH

🔧 Configuration : Feeder + Jaw crusher + cone crusher +vibrating screen



PROJECT CASES



📍 Project place : Tanzania

📁 Project proposal: 3 in 1 mobile stone crusher

⚙️ Capacity : 100TPH

🔧 Configuration : Feeder + Impact Crusher + Vibrating screen



PROJECT CASES

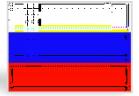

📍 Project place : Russia

📄 Project proposal: 2 in 1 mobile stone crusherX2

⚙️ Capacity : 200TPH

🔧 Configuration : Feeder +Jaw Crusher, Cone Crusher +vibrating screen



PROJECT CASES

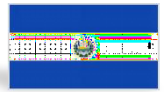

📍 Project place : Salvador

📁 Project proposal: stationary stone crushing plant

⚙️ Capacity : 40TPH

🔧 Configuration : Jaw crusher + Jaw crusher + Vibrating screen+ Belt conveyor



WHAT OUR PARTNERS SAY

AIMIX
AIMIX GROUP CO., LTD.

ФОРМА ОБРАТНОЙ СВЯЗИ ПОСЛЕПРОДАЖНОГО ОБСЛУЖИВАНИЯ
NO: 1920879

ПОКАЛУСТА, ПОМОГИТЕ НАМ УЛУЧШИТЬ НАШИ УСЛУГИ, ПОКАЛУСТА, ЗАПОЛНИТЕ НИЖЕПРИВЕДЕННУЮ О ВАШЕМ МНЕНИИ ФОРМУ ДОГОВОРА.
請您幫助我們改進我們的服務，請您填寫以下表格。

Рабочий адрес: 施工地址 Р. Умарал Б. Ишимов	Моб. номер: 电话 97.991-08-00 97.222-10-48
Обслуживание: 设备型号名称 Брмс Ас	Имя обслуживаемого: 设备编号 2022-12-22 2023-01-02
Специальный менеджер: 服务人员	Служба поддержки: 服务热线
Обслуживание: 服务内容 <input type="checkbox"/> Активный ответный визит <input type="checkbox"/> Обслуживание в рамках гарантии Служба сервисного обслуживания	Дополнительные комментарии: 其他信息
Объем работы: 工作量 Мелкие работы и ремонт: 处理方法和结果: Служба сервисного обслуживания: 1. Замена деталей; 2. Технический сервис. Итого:	Общая оценка: 总体评价: Пользовательская оценка (по 5 баллам): 客户满意度 (按 5 分制): <input checked="" type="checkbox"/> Очень хорошо (100%) <input type="checkbox"/> Хорошо (80%) <input type="checkbox"/> Нормально (60%) <input type="checkbox"/> Плохо (20%) <input type="checkbox"/> Неудовлетворительно
Другие комментарии: 用户意见 Короче работала Брмс Ас. Именная записка в сервис.	Спасибо за выбор продукции AIMIX ВАШЕ УДОВОЛЬСТВИЕ НАШ УСПЕХ. 感谢您选择我们采购机械设备有限公司产品，为您提供高品质产品和服务，是我们要不懈的追求。

AIMIX After sales Service Contact T: 0086 371 5515 9266 Mobile: 0086 131 3790 0391 E: aimix-service@aimixgroup.com

AIMIX AIMIX GROUP
RECOMMENDATION LETTER

Recommendation Letter
Experience with Aimix

We had purchased 1 unit of AS25m³ mobile concrete mixer from Aimix.

It was delivered in a standard shipping container.

The machine required to be assembly at our work site.

Aimix had sent Mr. Gasy (engineer/technician) to guide and assist us with the assembly works.

It was conducted professionally and swiftly with the technical support from Aimix team.

Training and guidance of the operation of the machine was also provided on-site at the work site.

We are very happy and satisfy with the services provided by Aimix.

7/19/2023

E-MAIL: MARKETING@AIMIXGROUP.COM
WEB: WWW.AIMIXGROUP.COM

AIMIX AIMIX GROUP CO., LTD.

Рекомендация по качеству продукции и этапу обслуживания

Пользователь: _____

Наименование оборудования: _____

Имя обслуживаемого: _____

Обслуживание: _____

Объем работы: _____

Другие комментарии: _____

Спасибо за выбор продукции AIMIX ВАШЕ УДОВОЛЬСТВИЕ НАШ УСПЕХ.
感谢您选择我们采购机械设备有限公司产品，为您提供高品质产品和服务，是我们要不懈的追求。

AIMIX AIMIX GROUP CO., LTD.

Предоставление информации о продукции и обслуживании

Пользователь: _____

Наименование оборудования: _____

Имя обслуживаемого: _____

Обслуживание: _____

Объем работы: _____

Другие комментарии: _____

Спасибо за выбор продукции AIMIX ВАШЕ УДОВОЛЬСТВИЕ НАШ УСПЕХ.
感谢您选择我们采购机械设备有限公司产品，为您提供高品质产品和服务，是我们要不懈的追求。

AIMIX AIMIX GROUP CO., LTD.

ФОРМА ОБРАТНОЙ СВЯЗИ ПОСЛЕПРОДАЖНОГО ОБСЛУЖИВАНИЯ
NO: 1920882

ПОКАЛУСТА, ПОМОГИТЕ НАМ УЛУЧШИТЬ НАШИ УСЛУГИ, ПОКАЛУСТА, ЗАПОЛНИТЕ НИЖЕПРИВЕДЕННУЮ О ВАШЕМ МНЕНИИ ФОРМУ ДОГОВОРА.
請您幫助我們改進我們的服務，請您填寫以下表格。

Рабочий адрес: 施工地址 P. Карим	Моб. номер: 电话 97.287.0111
Обслуживание: 设备型号名称 Брмс 300	Имя обслуживаемого: 设备编号 2022-09-25 2023-07-02
Специальный менеджер: 服务人员 М. Букиев	Служба поддержки: 服务热线
Обслуживание: 服务内容 <input type="checkbox"/> Активный ответный визит <input type="checkbox"/> Обслуживание в рамках гарантии Служба сервисного обслуживания	Дополнительные комментарии: 其他信息
Объем работы: 工作量 Мелкие работы и ремонт: 处理方法和结果: Служба сервисного обслуживания: 1. Замена деталей; 2. Технический сервис. Итого:	Общая оценка: 总体评价: Пользовательская оценка (по 5 баллам): 客户满意度 (按 5 分制): <input type="checkbox"/> Очень хорошо (100%) <input type="checkbox"/> Хорошо (80%) <input type="checkbox"/> Нормально (60%) <input type="checkbox"/> Плохо (20%) <input type="checkbox"/> Неудовлетворительно
Другие комментарии: 用户意见 Короче работала Брмс 300. Именная записка в сервис.	Спасибо за выбор продукции AIMIX ВАШЕ УДОВОЛЬСТВИЕ НАШ УСПЕХ. 感谢您选择我们采购机械设备有限公司产品，为您提供高品质产品和服务，是我们要不懈的追求。

AIMIX After sales Service Contact T: 0086 371 5515 9266 Mobile: 0086 131 3790 0391 E: aimix-service@aimixgroup.com

AIMIX AIMIX GROUP CO., LTD.

Recommendation Letter

We had purchased 1 unit of AS25m³ mobile concrete mixer from Aimix.

It was delivered in a standard shipping container.

The machine required to be assembly at our work site.

Aimix had sent Mr. Gasy (engineer/technician) to guide and assist us with the assembly works.

It was conducted professionally and swiftly with the technical support from Aimix team.

Training and guidance of the operation of the machine was also provided on-site at the work site.

We are very happy and satisfy with the services provided by Aimix.

7/19/2023

E-MAIL: MARKETING@AIMIXGROUP.COM
WEB: WWW.AIMIXGROUP.COM

AIMIX GLOBAL MARKET

AIMIX is a customer-center-oriented heavy equipment manufacturer and supplier, devoted to production, innovation, combination, one-stop solution, etc.

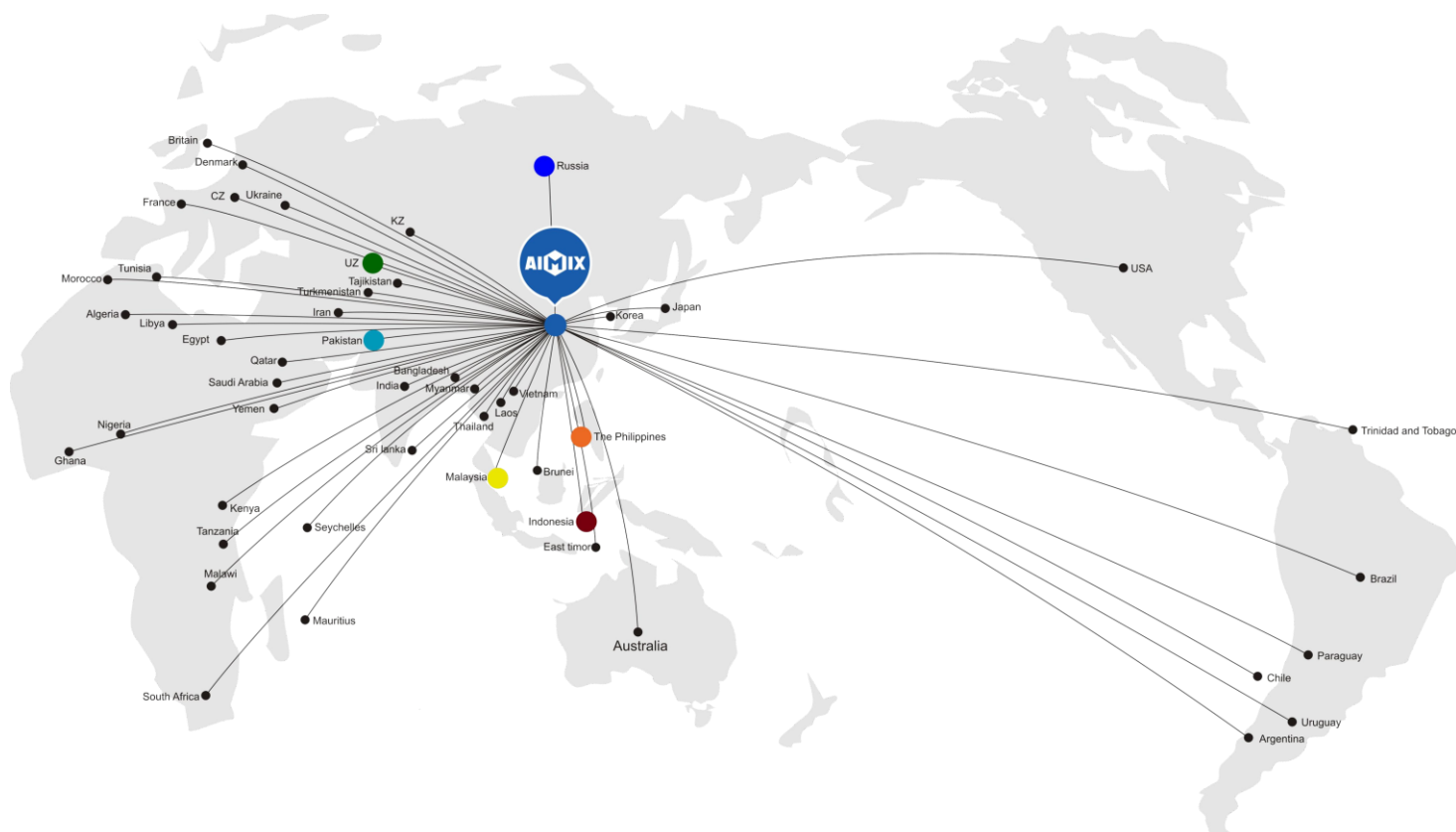

Customers' First Choices



Area of Factory



Exporting Countries



Branches



Production R&D experience

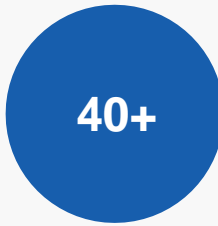

Techniques and Service team

A photograph of two business professionals, a man and a woman, shaking hands. The man is on the left, wearing a dark suit, and the woman is on the right, wearing a grey blazer. They are both smiling. The background is a plain, light-colored wall. The image is overlaid with a semi-transparent dark grey layer.

SOLUTION SPECIALIST FOR YOUR CONSTRUCTION PROJECT

**JOIN AIMIX,
BUILD A BETTER WORLD TOGETHER**



AIMIX GROUP CO., LTD.

